

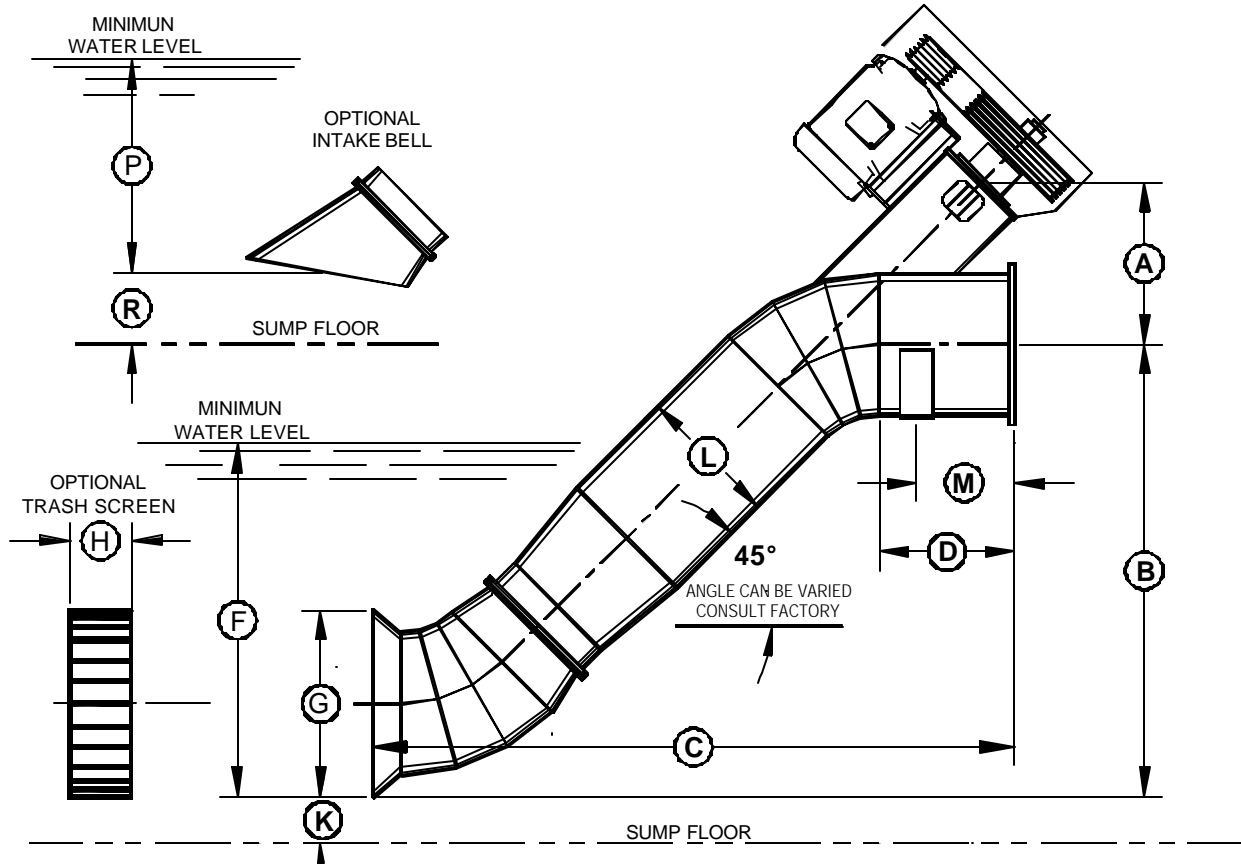

SINGLE STAGE ANGLED TYPE "AF" AXIAL FLOW PUMP BELT DRIVE / ELECTRIC MOTOR



STANDARD DIMENSIONS IN INCHES

PUMP SIZE	A MIN.	B MIN.	C MIN.	D	F MIN.	G	H	K	L	M	P	R	PUMP SIZE
8	10	36	48	10	30	12	6	4	8-5/8	8-1/2	24	8	8
10	12	36	48	14	32	15	6	4	10-3/4	12-1/2	24	8	10
12	15	42	54	14	32	16	6	4	12-3/4	12-1/2	24	8	12
14	18	48	62	18	38	18	6	4	14	16	27	9	14
16	20	54	70	18	42	21	8	6	16	16	32	10	16
18	22	64	84	18	48	24	10	6	18	16	36	12	18
20	25	74	96	18	54	27	10	6	20	16	41	13	20
24	30	78	100	18	62	32	14	8	24	16	48	16	24
30	38	104	135	24	76	39	16	8	30	21	59	19	30
36	45	126	164	24	90	45	20	8	36	21	68	22	36
42	52	138	180	30	106	54	24	12	42	26	81	27	42
48	60	138	180	36	124	63	28	12	48	32	95	31	48
54	68	148	192	36	142	72	32	12	54	32	108	36	54
60	75	158	204	46	160	81	36	12	60	41	120	40	60
72	90	182	236	46	200	99	36	12	72	41	148	49	72

NOTES:

DIMENSIONS A, B, C, & F ARE MINIMUM FOR STANDARD CONSTRUCTION.
 CONSULT FACTORY FOR CUSTOM CONFIGURATIONS TO SUIT YOUR APPLICATION.
 PUMP ANGLE CAN BE MODIFIED TO SUIT YOUR APPLICATION, CONSULT FACTORY FOR DIMENSIONS.
 PUMP DISCHARGE CAN BE FLANGED OR PLANE END FOR DRESSOR STYLE COUPLINGS.