

- 2 Impeller
- 6 Shaft, pump
- 12 Shaft, line
- 13 Packing
- 15 Bowl, discharge
- 17 Gland
- 24 Nut, impeller
- 29 Ring, lantern
- 32 Key, impeller
- 39 Bushing, bearing
- 42 Coupling half, driver
- 44 Coupling half, pump
- 46 Key, coupling
- 55 Bell, suction
- 63 Bushing, stuffing-box
- 64 Collar, protecting
- 66 Nut, shaft, adjusting
- 70 Coupling, shaft
- 82 Ring, thrust, retainer
- 83 Stuffing-box
- 86 Ring, thrust, split
- 101 Pipe, column
- 129 Sole plate
- 187 Head, surface discharge
- 193 Retainer bearing open lineshaft
- 209 Strainer (optional)

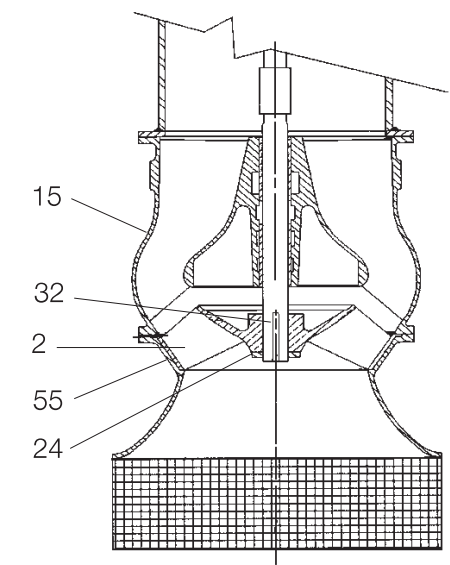

Bearing below impeller

Without bearing below impeller

Figure 2.8 — Mixed flow vertical – open line shaft