

FPI

Propeller Pumps Since 1937

SUBMERSIBLE ELECTRIC PUMPING EQUIPMENT

HIGH VOLUME AXIAL & MIXED FLOW PUMPS



- **VERSATILE**
- **COST EFFECTIVE**
- **HIGH EFFICIENCY**

TUBE MOUNTED

PUBLIC WORKS
STORM WATER DRAINAGE
DEWATERING
WATER TREATMENT
INDUSTRIAL

Member of:
Hydraulic
 INSTITUTE



I.S.O. 9001
 CERTIFIED

SUBMERSIBLE ELECTRIC MOTORS:

TYPE: TENV/UL approved CSA, Class 1 Groups C&D for Hazardous continuous duty 1.15 Service factor and capable of 15 minute operation in air. Motors have large cast iron frames to provide maximum heat dissipation, class F or H installation, stainless steel shafts, a tandem mechanical seal system and moisture detection warning device.

Automatic megger conductivity testing system is available for motor and cable insulation.

PROPELLER PUMP

Our standard pumps are manufactured in the most durable materials of construction available. These materials meet the severity of most applications providing extended service life. Those standards are:

- Stainless steel:
Propellers, flanged runner wear rings and pump shafts.
- ASTM 242 steel:
Discharge and bowl housings
Intake Bell and Bar rack
- Bearings: All rated B-10 life or better
- Mechanical seals: Dual carbon-ceramic type
- Speed reduction bowls:
Provided with planetary gear reducers
Pump housed thrust and radial bearings
Double mechanical seals

Pumps are also available in all stainless construction with dual tungsten carbide mechanical seals. A variety of protective coating materials are available for the entire assembly.

SYSTEM WARRANTY: Five (5) Years

TESTING:

In accord with the ANSI Hydraulic Institute Standards. Certified full size or scale model testing available..

FPI guarantees that only the highest quality components and materials will be used in all systems provided.

Our entire pump catalog can be mailed to you upon request. The catalog is available with complete pump performance curves, drawings and technical specifications on our web site www.fpipumps.com

FEATURES

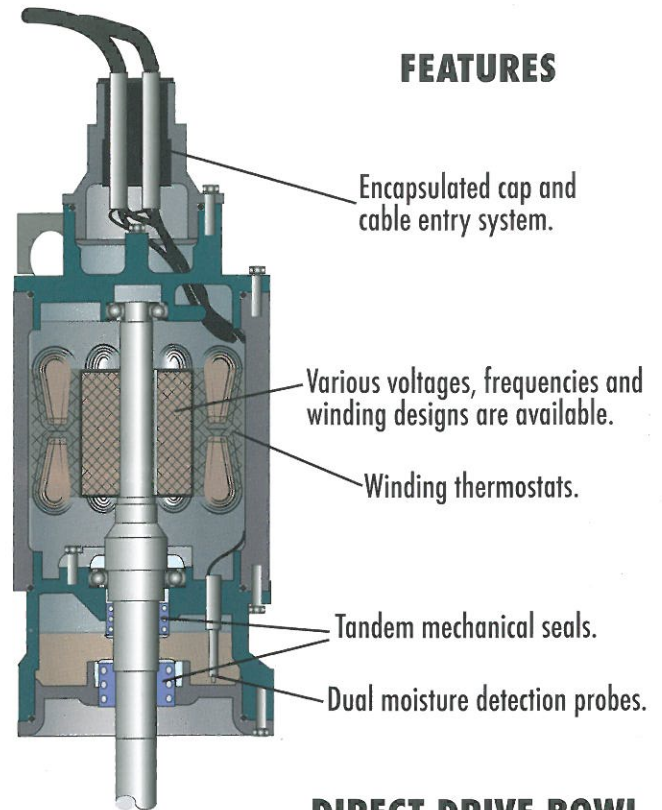

DIRECT DRIVE BOWL

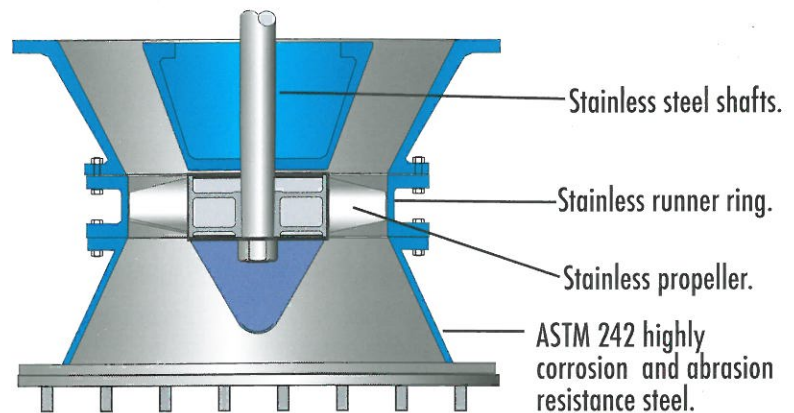

SPEED REDUCTION BOWL

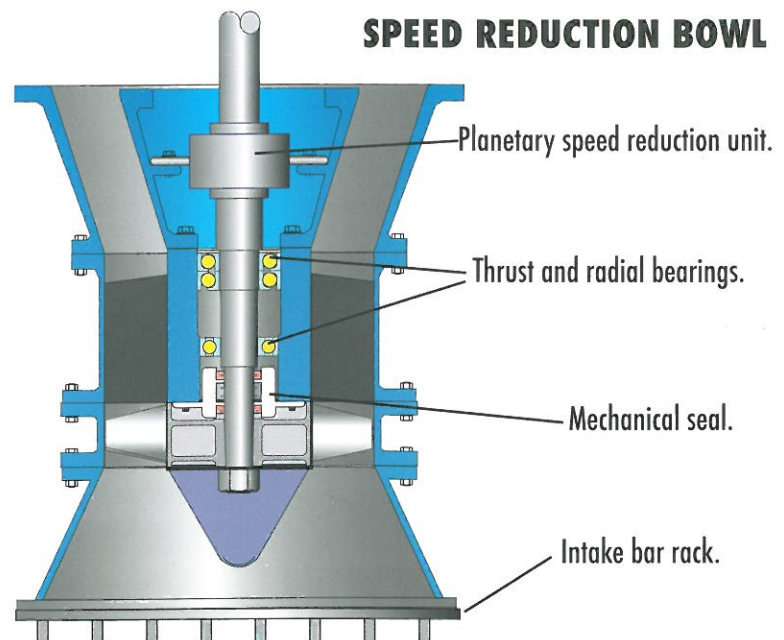

FPI's Submersible Electric Propeller Pump and Motor units provide a superior product with high mechanical efficiency, compact layout and ease of removal and installation. This allows pump station designers to develop major pumping facilities that are efficient, reliable and extremely cost-effective.

Use of Submersible Electric Pumps offer a wide range of unique applications that reduce facilities foot-print, make them non-intrusive and provide an effective alternative to the conventional pump station design.

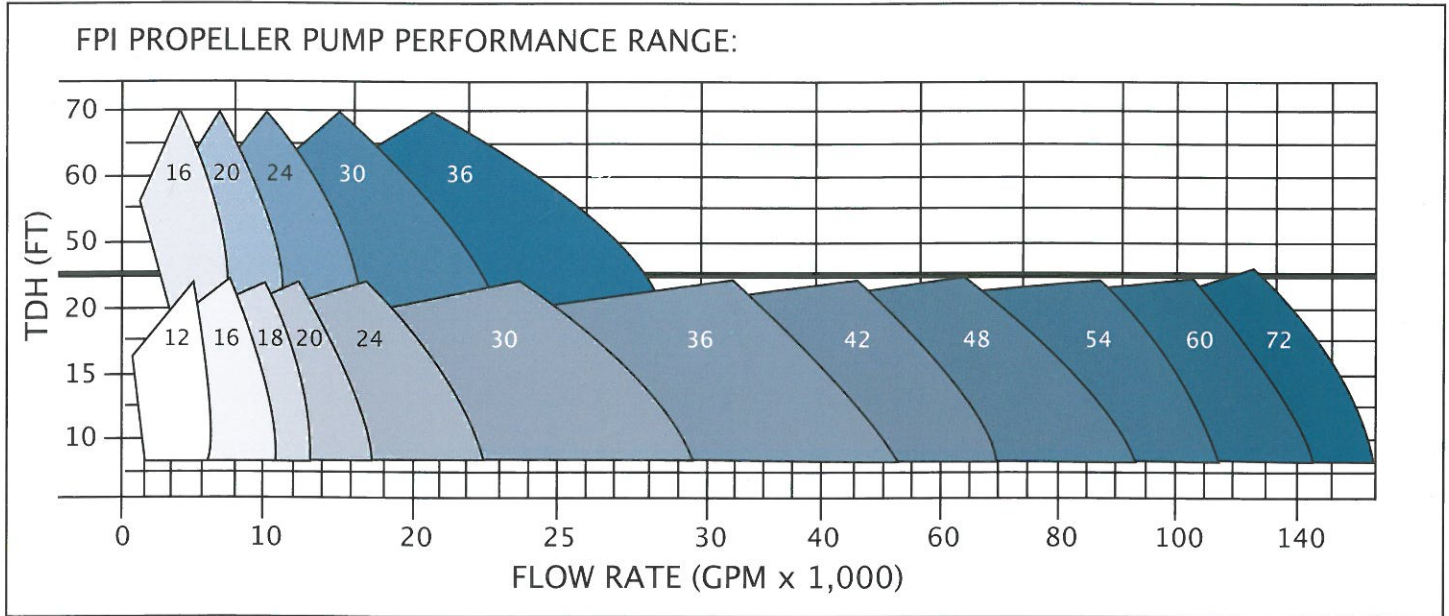

INSTALLATION CONFIGURATIONS

ADVANTAGES

- MINIMAL CIVIL WORKS
- NON INTRUSIVE STATION
- SMALL FOOT PRINT
- LOW NOISE
- EASY ACCESS
- LOW MAINTENANCE

ANGLE

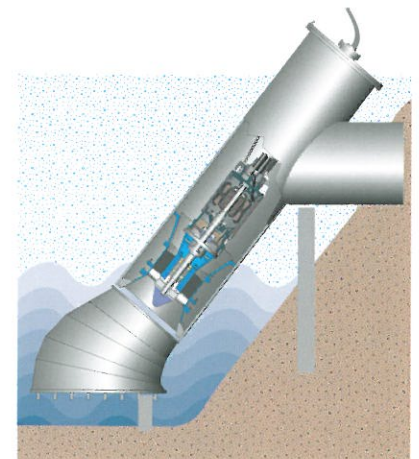

VERTICAL

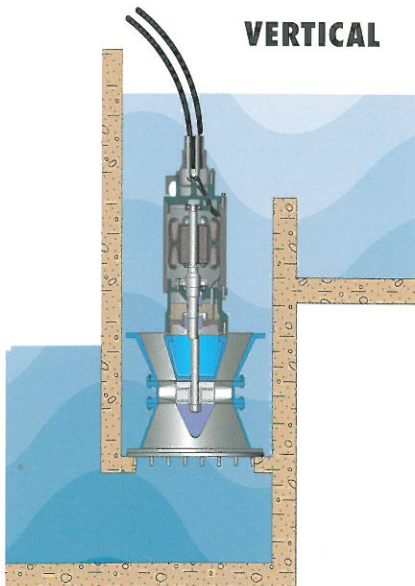

HORIZONTAL

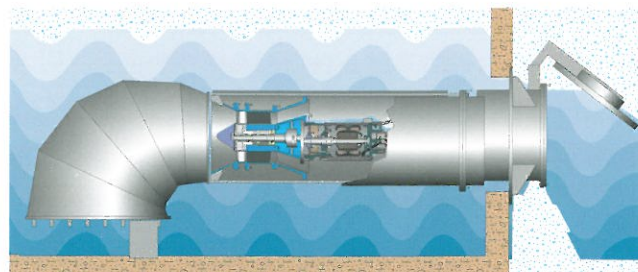

FPI, committed to superior pump manufacturing since 1937, is proud to offer our highly efficient and cost effective Submersible Electric Axial and Mixed Flow Pumps.

The design of these pumps is the culmination of almost 70 years in Water Pump Technology matched with 45 years of submersible motor experience. This union is the design achievement delivering the most reliable propeller pump system available today!

You can rely on FPI to deliver superior pumps to support all Large Volume Water Management Control System Projects

ACCESSORIES EQUIPMENT:

To complete a pump station design package, FPI offers complementary support equipment meeting the system requirements. These include the following: Motor Control Centers incorporating soft starting or Variable Frequency pump speed drives which improve energy efficiency; digital level controller, level sensor transducers, ultrasonic or float control; motor and cable automatic megger monitoring and testing devices; Stand-By Power Generators and companion switch gear for unmanned automatic pump station operation. FPI also offers Installation Service and Maintenance Contracts.



Advanced digital Level controller



Master Control Center (MCC)
soft starting gear



V.F.D. variable pump speed
frequency controllers



Auto megger insulation testing
and monitor for motors,
cables and generators.



Water level transducer and non
intrusive ultrasonic sensors.



Mechanical float
control switches.



Stand-by power generators.

This literature is descriptive. F.P.I. manufactures what we refer to as "Our Standard Pumps", however, we build all of our units to meet a designers flow and discharge head requirements. We offer our Engineering experience and assistance in the development of Intake-Sump Design and provide you with detailed pump technical data, performance curves and equipment specifications.

Please call our Engineering Department

WORLDWIDE SALES OFFICES

FPI HEADQUARTERS:

814 NW 3RD STREET, POMPANO BEACH FLORIDA 33060

PHONE: (954) 946-3066 • FAX:(954) 946-3111

E-MAIL: sales@fpipumps.com

WEBSITE: www.fpipumps.com